

Sample Question Paper - 17
Mathematics-Basic (241)
Class- X, Session: 2021-22
TERM II

Time Allowed: 120 minutes

Maximum Marks: 40

General Instructions:

1. The question paper consists of 14 questions divided into 3 sections A, B, C.
2. All questions are compulsory.
3. Section A comprises of 6 questions of 2 marks each. Internal choice has been provided in two questions.
4. Section B comprises of 4 questions of 3 marks each. Internal choice has been provided in one question.
5. Section C comprises of 4 questions of 4 marks each. An internal choice has been provided in one question. It contains two case study based questions.

SECTION A

1. Find the nature of the roots of the following quadratic equation. If the real roots exist, find them : $3x^2 - 4\sqrt{3}x + 4 = 0$

OR

Find the nature of roots of the quadratic equation $x^2 + x - 5 = 0$.

2. How many terms of the AP : 9, 17, 25,must be taken to give a sum 636?
3. If the sum of first m terms of an AP is the same as the sum of its first n terms, show that the sum of its first $(m + n)$ terms is zero.
4. To draw a pair of tangents to a circle which are inclined to each other at an angle of 55° , it is required to draw tangents at the end points of these two radii of the circle, what is the angle between two radii?
5. A solid is in the shape of a cone surmounted on a hemisphere. The radius of each of them being 3.5 cm and the total height of the solid is 9.5 cm. Find the volume of the solid.
6. Find the mode of the following data :

Class :	0-20	20-40	40-60	60-80	80-100	100-120	120-140
Frequency	6	8	10	12	6	5	3

OR

The mean weight of 9 students is 25 kg. If one more student is joined in the group the mean is unaltered, then find the weight of the 10th student.

Section B

7. The angle of elevation of the top of a building from the foot of a tower is 30° and the angle of elevation of the top of a tower from the foot of the building is 60° . If the tower is 50 m high, then find the height of the building.
8. Draw a pair of tangents to a circle of radius 4 cm which are inclined to each other at an angle of 45° .



9. A solid is in the shape of a hemisphere surmounted by a cone. If the radius of hemisphere and base radius of cone is 7 cm and height of cone is 3.5 cm, find the volume of the solid. (Take $\pi = \frac{22}{7}$)
10. If the mean of the following data is 14.7, find the values of p and q .

Class	0-6	6- 12	12-18	18-24	24-30	30-36	36-42	Total
Frequency	10	p	4	7	q	4	1	40

OR

Compute the median from the following data :

Mid-values	115	125	135	145	155	165	175	185	195
Frequency	6	25	48	72	116	60	38	22	3

Section C

11. As observed from the top of a light house, 100 m high above sea level, the angles of depression of a ship, sailing directly towards it, changes from 30° to 60° . Find the distance travelled by the ship during the period of observation. (Use $\sqrt{3} = 1.73$)
12. If the angle between two tangents drawn from an external point P to a circle of radius a and centre O , is 60° , then find the length of OP .

OR

In the given figure, PA and PB are tangents to the circle from an external point P . CD is another tangent touching the circle at Q . If $PA = 12$ cm, $QC = QD = 3$ cm, then find $PC + PD$.

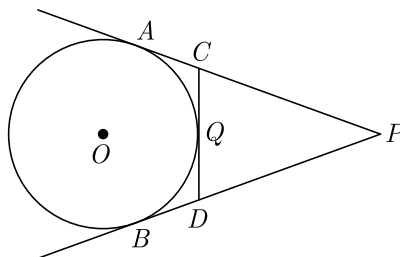

13. Arc of a Baby Swing : When Mackenzie's baby swing is started, the first swing (one way) is a 30 inch arc. As the swing slows down, each successive arc is 1.5 inch less than the previous one.
- Find the length of the tenth swing.
 - How far Mackenzie has travelled during the 10 swings ?



14. Air Quality Index : AQI is an index for reporting air quality on a daily basis. The purpose of the AQI is to help people know how the local air quality impacts their health. The Environmental Protection Agency (EPA) calculates the AQI for five major air pollutants :

1. Ground-level ozone
2. Particle pollution/particulate matter (PM_{2.5}/pm 10)
3. Carbon Monoxide
4. Sulfur dioxide
5. Nitrogen dioxide

The higher the AQI value, the greater the level of air pollution and the greater the health concerns.

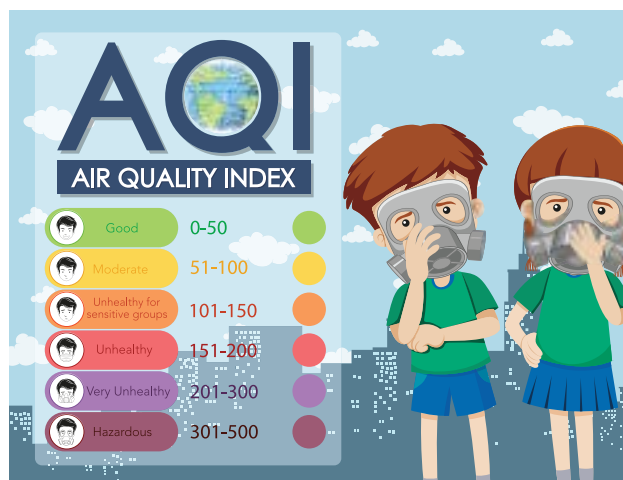

Following frequency distribution shows the Air Quality Index of different localities of Delhi on 27th December 2020 reported by Times of India Newspaper on 28th December 2020.

AIQ	Number of weeks f
270-280	4
280-290	10
290-300	14
300-310	20
310-320	24
320-330	8
Total	80

Based on the above information, answer the following questions.

- (i) Estimate the mean AQI.
- (ii) What is the median AQI?

Solution
MATHEMATICS BASIC 241
Class 10 - Mathematics

Time Allowed: 120 minutes

Maximum Marks: 40

General Instructions:

1. The question paper consists of 14 questions divided into 3 sections A, B, C.
2. All questions are compulsory.
3. Section A comprises of 6 questions of 2 marks each. Internal choice has been provided in two questions.
4. Section B comprises of 4 questions of 3 marks each. Internal choice has been provided in one question.
5. Section C comprises of 4 questions of 4 marks each. An internal choice has been provided in one question. It contains two case study based questions.

SECTION A

1. Find the nature of the roots of the following quadratic equation. If the real roots exist, find them : $3x^2 - 4\sqrt{3}x + 4 = 0$

Sol :

We have $3x^2 - 4\sqrt{3}x + 4 = 0$

Comparing with $ax^2 + bx + c = 0$ we get

$$a = 3, b = -4\sqrt{3}, c = 4$$

$$b^2 - 4ac = (-4\sqrt{3})^2 - 4(3)(4) \\ = 48 - 48 = 0$$

Thus roots are real and equal.

Roots are $\left(-\frac{b}{2a}\right), \left(-\frac{b}{2a}\right)$ or $\frac{2\sqrt{3}}{3}, \frac{2\sqrt{3}}{3}$

or

Find the nature of roots of the quadratic equation $x^2 + x - 5 = 0$.

Sol :

We have $x^2 + x - 5 = 0$

Here, $a = 1, b = 1, c = -5$

Now, $D = b^2 - 4ac \\ = (1)^2 - 4 \times 1 \times (-5) \\ = 21 > 0$

So $x^2 + x - 5 = 0$ has two distinct real roots.

2. How many terms of the AP : 9, 17, 25, must be taken to give a sum 636?

Sol :

Given, AP is 9, 17, 25,

and $S_n = 636$

Here, $a = 9, d = 17 - 9 = 8$

Now, $S_n = \frac{n}{2}[2a + (n - 1)d]$

$$636 = \frac{n}{2}[2 \times 9 + (n - 1)8]$$

$$1272 = n[18 + 8n - 8]$$

$$1272 = n(10 + 8n)$$

$$8n^2 + 10n - 1272 = 0$$

$$4n^2 + 5n - 363 = 0$$

Now, $n = \frac{-5 \pm \sqrt{25 - 4 \times 4 \times (-363)}}{2 \times 4}$

$$= \frac{-5 \pm \sqrt{25 + 10176}}{8}$$

$$= \frac{-5 \pm \sqrt{10201}}{8}$$

$$= \frac{-5 \pm 101}{8}$$

Thus $n = \frac{-5 + 101}{8}, = \frac{-5 - 101}{8}$

$$n = \frac{96}{8} \text{ or } \frac{-106}{8}$$

$$n = 12 \text{ or } \frac{-53}{4}$$

Since n can not be negative, $n = 12$

3. If the sum of first m terms of an AP is the same as the sum of its first n terms, show that the sum of its first $(m+n)$ terms is zero.

Sol :

Let a be the first term and d be the common difference of the given AP. Then,

$$S_m = S_n$$

$$\frac{m}{2} \{2a + (m-1)d\} = \frac{n}{2} \{2a + (n-1)d\}$$

$$2a(m-n) + \{m(m-1) - n(n-1)\}d = 0$$

$$2a(m-n) + [(m^2 - n^2) - (m-n)d] = 0$$

$$(m-n)[2a + (m+n-1)d] = 0$$

$$2a + (m+n-1)d = 0$$

$$\text{Now, } S_{m+n} = \frac{m+n}{2} \{2a + (m+n-1)d\}$$

$$= \frac{m+n}{2} \times 0 = 0$$

4. To draw a pair of tangents to a circle which are inclined to each other at an angle of 55° , it is required to draw tangents at the end points of these two radii of the circle, what is the angle between two radii?

Sol :

According to the question we can draw the following diagram.

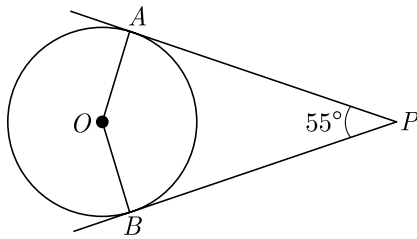

From figure,

$$\angle AOB + \angle APB = 180^\circ$$

$$\angle AOB = 180^\circ - \angle APB$$

$$= 180^\circ - 55^\circ = 125^\circ$$

5. A solid is in the shape of a cone surmounted on a hemisphere. The radius of each of them being 3.5 cm and the total height of the solid is 9.5 cm. Find the volume of the solid.

Sol :

As per question the figure is shown below. Here total volume of the toy is equal to the sum of volume of hemisphere and cone.

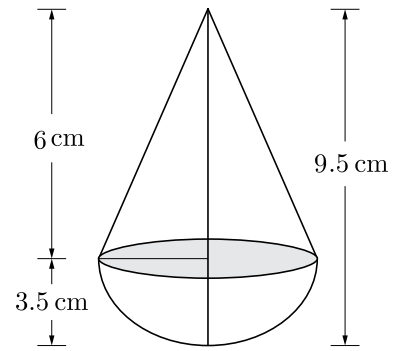

Volume of toy,

$$\frac{1}{3}\pi r^2 h + \frac{2}{3}\pi r^3 = \frac{1}{3}\pi r^2 (h + 2r)$$

$$= \frac{1}{3} \times \frac{22}{7} \times (3.5)^2 \times (6 + 2 \times 3.5)$$

$$= \frac{1}{3} \times \frac{22}{7} \times 3.5 \times 3.5 \times (6 + 7)$$

$$= \frac{1}{3} \times \frac{22}{2} \times 3.5 \times 13$$

$$= \frac{1}{3} \times 11 \times 3.5 \times 13$$

$$= \frac{500.5}{3} = 166.83 \text{ cm}^3 \quad (\text{Approx})$$

Hence, the volume of the solid is 166.83 cm^3 .

6. Find the mode of the following data :

Class :	0-20	20-40	40-60	60-80	80-100	100-120	120-140
Frequency	6	8	10	12	6	5	3

Sol :

Class 60-80 has the maximum frequency 12, therefore this is modal class.

Hence, $l = 60$, $f_1 = 12$, $f_0 = 6$, $f_2 = 6$ and $h = 20$

$$\text{Mode, } M_o = l + \left(\frac{f_1 - f_0}{2f_1 - f_0 - f_2} \right) h$$

$$= 60 + \frac{12 - 6}{2 \times 12 - 6 - 6} \times 20$$

$$= 60 + \frac{2 \times 20}{24 - 12} = 60 + \frac{40}{12}$$

$$= 60 + 5 = 65$$

or

The mean weight of 9 students is 25 kg. If one more student is joined in the group the mean is unaltered, then find the weight of the 10th student.

Sol :



The sum of the weights of the 9 students = $25 \times 9 = 225$. If one more student is joined in the group, then total number of students is 10 and mean is 25.

Hence, the sum of the weights of the 10th students = $25 \times 10 = 250$.

Hence, the weight of the 10th student is $250 - 225 = 25$ kg.

However we can answer this question without any calculation. If mean is not altered on adding more data, then added data must be of mean value.

Section B

7. The angle of elevation of the top of a building from the foot of a tower is 30° and the angle of elevation of the top of a tower from the foot of the building is 60° . If the tower is 50 m high, then find the height of the building.

Sol :

As per given information in question we have drawn the figure below.

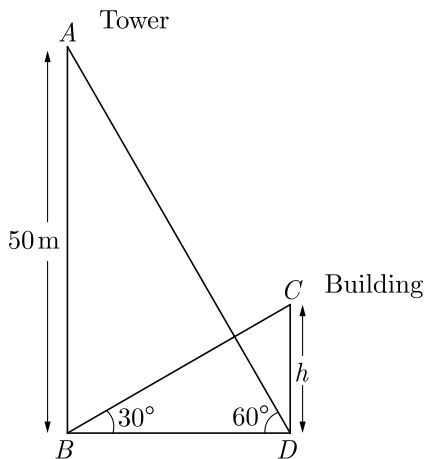

$$\text{In } \triangle ABD, \quad \tan 60^\circ = \frac{AB}{BD}$$

$$\sqrt{3} = \frac{50}{BD}$$

$$BD = \frac{50}{\sqrt{3}}$$

$$\text{Now in } \triangle BDC, \quad \tan 30^\circ = \frac{CD}{BD}$$

$$\frac{1}{\sqrt{3}} = \frac{h}{\frac{50}{\sqrt{3}}} = \frac{h\sqrt{3}}{50}$$

$$3h = 50$$

$$h = \frac{50}{3} = 16.67$$

Hence, the height of the building is 16.67 m.

8. Draw a pair of tangents to a circle of radius 4 cm which are inclined to each other at an angle of 45° .

Sol :

Steps of Construction:

- Draw a circle with O and radius 4 cm.
- Draw any diameter AOB of this circle.
- Draw the radius OR meets the circle at R such that $\angle BOR = 45^\circ$.
- Draw $AD \perp AB$ and $RE \perp OR$, which intersects each other at T .

Then, TA and TR are the required tangents.

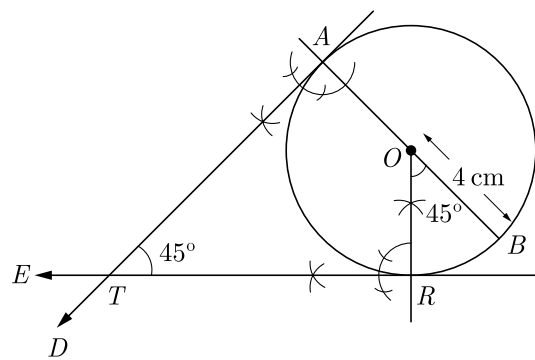

9. A solid is in the shape of a hemisphere surmounted by a cone. If the radius of hemisphere and base radius of cone is 7 cm and height of cone is 3.5 cm, find the volume of the solid. (Take $\pi = \frac{22}{7}$)

Sol :

As per given information in question we have drawn the figure below,

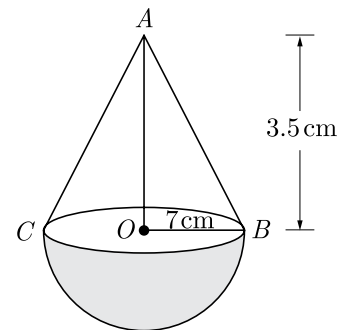

Here, radius $r = 7$ cm

and height of a cone = 3.5 cm

Volume of the solid,

$$= \text{Volume of hemisphere} + \text{volume of a cone}$$

$$\begin{aligned}
&= \frac{2}{3}\pi r^3 + \frac{1}{3}\pi r^2 h \\
&= \frac{2}{3} \times \frac{22}{7} \times 7^3 + \frac{1}{3} \times \frac{22}{7} \times 7^3 \times 3.5 \\
&= \frac{1}{3}(2156 + 539) = \frac{1}{3} \times 2695 = 898.33 \text{ cm}^3
\end{aligned}$$

10. If the mean of the following data is 14.7, find the values of p and q .

Class	0-6	6-12	12-18	18-24	24-30	30-36	36-42	Total
Frequency	10	p	4	7	q	4	1	40

Sol :

Class	x_i	f_i	$f_i x_i$
0-6	3	10	30
6-12	9	p	$9p$
12-18	15	4	60
18-24	21	7	147
24-30	27	q	$27q$
30-36	33	4	132
36-42	39	1	39
Total		$\sum f_i = 26 + p + q = 40$	$\sum f_i x_i = 408 + 9p + 27q$

We have $\sum f_i = 40$,

$$26 + p + q = 40$$

$$p + q = 14 \quad \dots(1)$$

Mean $M = \frac{\sum x_i f_i}{\sum f_i}$

$$14.7 = \frac{408 + 9p + 27q}{40}$$

$$588 = 408 + 9p + 27q$$

$$180 = 9p + 27q$$

$$p + 3q = 20 \quad \dots(2)$$

Subtracting equation (1) from (2) we have,

$$2q = 6 \Rightarrow q = 3$$

Substituting this value of q in equation (2) we get

$$p = 14 - q = 14 - 3 = 11$$

Hence, $p = 11, q = 3$

or

Compute the median from the following data :

Mid-values	115	125	135	145	155	165	175	185	195
Frequency	6	25	48	72	116	60	38	22	3

Sol :

Here, the mid-values are given So, we should first find the upper and lower limits of the various classes. The difference between two consecutive values is $h = 125 - 115 = 10$

$$\text{Lower limit of a class} = \text{Mid-value} - \frac{h}{2}$$

$$\text{Upper limit} = \text{Mid-value} + \frac{h}{2}$$

Mid-value	Class Groups	Frequency	Cumulative Frequency
115	110-120	6	6
125	120-130	25	31
135	130-140	48	79
145	140-150	72	151
155	150-160	116	267
165	160-170	60	327
175	170-180	38	365
185	180-190	22	387
195	190-200	3	390

Now $N = 390; \frac{N}{2} = 195$

Cumulative frequency just greater than $\frac{N}{2}$ is 36 and the corresponding class is 150-160. Thus median class is 150-160.

Here, $l = 150, f = 116, h = 10, F = 151$

$$\begin{aligned}
\text{Median, } M_d &= l + \left(\frac{\frac{N}{2} - F}{f} \right) h \\
&= 150 + \frac{195 - 151}{116} \times 10 \\
&= 153.8
\end{aligned}$$

Section C

11. As observed from the top of a light house, 100 m high above sea level, the angles of depression of a ship, sailing directly towards it, changes from 30° to 60° . Find the distance travelled by the ship during the period of observation. (Use $\sqrt{3} = 1.73$)

Sol :

Let AB be the light house of height 100 m. Let C and D be the position of ship at elevation 60° and 30° . As per given in question we have drawn figure below.

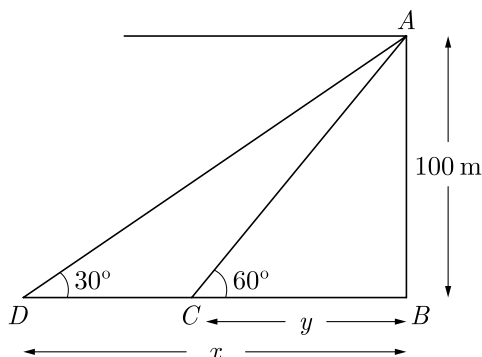

In right $\triangle ABC$ we have

$$\frac{AB}{BC} = \tan 60^\circ$$

$$\frac{100}{y} = \sqrt{3} \rightarrow y = \frac{100}{\sqrt{3}}$$

In right $\triangle ABD$, we have

$$\frac{AB}{BD} = \tan 30^\circ$$

$$\frac{100}{x} = \frac{1}{\sqrt{3}}$$

$$x = 100\sqrt{3}$$

Distance CD travelled by ship,

$$x - y = 100\sqrt{3} - \frac{100}{\sqrt{3}} \text{ m}$$

$$= 100 \left[\frac{3 - 1}{\sqrt{3}} \right] = \frac{100 \times 2}{\sqrt{3}}$$

$$= \frac{200}{\sqrt{3}} = \frac{200\sqrt{3}}{3}$$

$$= \frac{200 \times 1.73}{3} = \frac{3.46}{3} \text{ m} = 115.33 \text{ m}$$

12. If the angle between two tangents drawn from an external point P to a circle of radius a and centre O , is 60° , then find the length of OP .

Sol :

As per the given question we draw the figure as below.

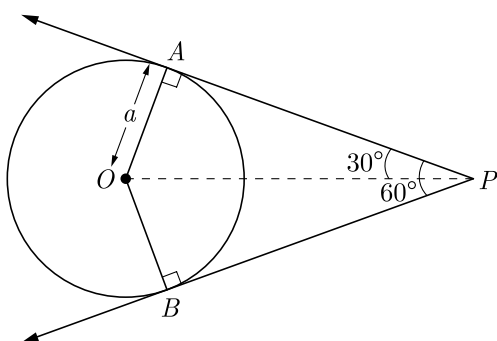

Tangents are always equally inclined to line joining the external point P to centre O .

$$\angle APO = \angle BPO = \frac{60^\circ}{2} = 30^\circ$$

Also radius is also perpendicular to tangent at point of contact.

In right $\triangle OAP$ we have,

$$\angle APO = 30^\circ$$

Now, $\sin 30^\circ = \frac{OA}{OP}$

Here OA is radius whose length is a , thus

$$\frac{1}{2} = \frac{a}{OP}$$

or $OP = 2a$

or

In the given figure, PA and PB are tangents to the circle from an external point P . CD is another tangent touching the circle at Q . If $PA = 12$ cm, $QC = QD = 3$ cm, then find $PC + PD$.

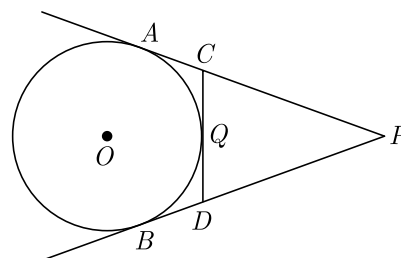

Sol :

Since length of tangents from an external point to a circle are equal,

$$CA = CQ = 3 \text{ cm}$$

$$DQ = DB = 3 \text{ cm}$$

and

$$PB = PA = 12 \text{ cm}$$

$$PA + PB = PC + CA + PD + DB$$

$$PC + PD = PA - CA + PB - DB$$

$$= 12 - 3 + 12 - 3 = 18 \text{ cm}$$

13. Air Quality Index : AQI is an index for reporting air quality on a daily basis. The purpose of the AQI is to help people know how the local air quality impacts their health. The Environmental Protection Agency (EPA) calculates the AQI for five major air pollutants

1. Ground-level ozone
2. Particle pollution/particulate matter (PM_{2.5}/pm 10)
3. Carbon Monoxide
4. Sulfur dioxide

5. Nitrogen dioxide

The higher the AQI value, the greater the level of air pollution and the greater the health concerns.

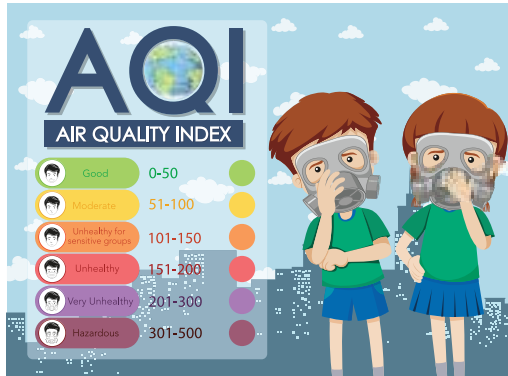

Following frequency distribution shows the Air Quality Index of different localities of Delhi on 27th December 2020 reported by Times of India Newspaper on 28th December 2020.

AIQ	Number of weeks f
270-280	4
280-290	10
290-300	14
300-310	20
310-320	24
320-330	8
Total	80

Based on the above information, answer the following questions.

- (i) Estimate the mean AQI.
- (ii) What is the median AQI?

Sol :

- (i) We prepare the following commutative frequency distribution table.

AIQ	Number of weeks f	cf	Mid-point x_i	$f_i x_i$
270-280	4	4	275	1100
280-290	10	14	285	2850
290-300	14	28	295	4130
300-310	20	48	305	6100
310-320	24	72	315	7560
320-330	8	80	325	2600
Total	80			24340

$$\text{Mean} = \frac{\sum f_i x_i}{\sum f_i} = \frac{24340}{80} = 304.25$$

- (ii) Here $l = 300$, $N = 80$, $F = 28$, $f = 20$ and $h = 10$
Cumulative frequency just greater than $\frac{N}{2} = \frac{80}{2} = 40$ is 48 and the corresponding class is 300-310. Thus median class is 300-310.

$$\begin{aligned} \text{Median, } M_d &= l + \left(\frac{\frac{N}{2} - F}{f} \right) h \\ &= 300 + \left(\frac{40 - 28}{20} \right) \times 10 \\ &= 300 + 6 = 306 \end{aligned}$$

- 14. Arc of a Baby Swing : When Mackenzie's baby swing is started, the first swing (one way) is a 30 inch arc. As the swing slows down, each successive arc is 1.5 inch less than the previous one.

- (i) Find the length of the tenth swing.
- (ii) How far Mackenzie has travelled during the 10 swings ?



Sol :

Mackenzie's baby swing form a arithmetic sequence.

Here $a_1 = 30$, $d = \frac{-3}{2}$, $n = 10$

(i) $a_n = a_1 + (n - 1) d$

$$\begin{aligned} a_{10} &= 30 + (10 - 1) \left(\frac{-3}{2} \right) = 30 + 9 \left(\frac{-3}{2} \right) \\ &= 30 - \frac{27}{2} = 30 - 13.5 \end{aligned}$$

$a_{10} = 16.5$ inches

(ii) $S_n = \frac{n(a_1 + a_n)}{2}$

$$\begin{aligned} S_{10} &= \frac{10(30 + 16.5)}{2} = \frac{10(46.5)}{2} \\ &= 232.5; \text{ inches} \end{aligned}$$